

Star 12 / 24 – Industrial LED Bulkhead Light

Industrial LED Bulkhead Range

Star 12 XL110 AC
Star 12 XL110 DC

Star 24 XL110 AC
Star 24 XL110 DC

Alternative Products

Sun - LED Floodlight Range

Sun 12 XL110 AC
Sun 12 XL110 DC

Sun 24 XL110 AC
Sun 24 XL110 DC

The **Star 12 / 24 LED 2D Bulkhead lights** are environmentally friendly replacements for traditional 2D bulkhead light fittings.

Typically using 50% less energy, these LED lights can significantly reduce energy consumption and cut carbon emissions. Ideal for reducing expenditure and helping with environmental issues.

These LED 2D Bulkhead lights are ready for connection to either AC mains power supply or our Mercury solar power management unit on request, which provides a flexible lighting solution where mains power is not available or desired.

The Star LED 2D Bulkhead Light is IP65 rated and comes in a vandal resistant fitting manufactured from strong pressure die-cast aluminium, with a flame-retardant polycarbonate cover and tamper-resistant cover screws as standard.

These luminaires are ideal for use in security area, subways, pedestrian areas, multi storey car parks and any environment prone to vandalism.

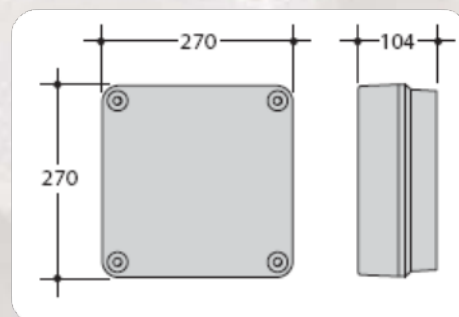
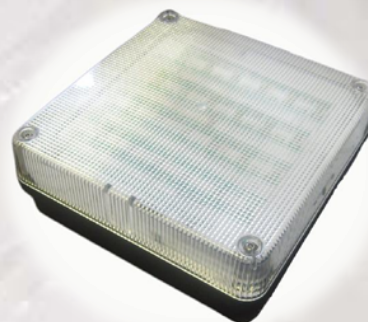

Specifications: Star 12 / 24 XL110 – Industrial LED Bulkhead Light

	AC	
Product Code	ST12-A001-D2	ST24-A001-D2
Power Consumption LED's	13.68 Watts	27.36 Watts
Power Consumption Driver	4.5 Watts	
Total Power Consumption	18.18 Watts	31.86 Watts
Input Voltage	90 – 264Vac	
Input Frequency	47 – 63Hz	
Light Source	1.14 W High Power LED	
LED QTY	12	24
Total LED Output	1320 lm	2640 lm
Operating Lumens at 25°C	1056 lm	2112 lm
LED Colour	Cool White	
Colour Temp (K)	5400 - 6300 degrees K (Standard)	
CRI	Ra>70	
LED Lifespan	50,000 > 80,000 Hours	
Operating Temperature	-30 degrees C to + 50 degrees C	
Working Humidity	0 ~ 95%	
Turn on time	100ns	
Product Size (mm)	270mm x 270mm x 104mm	
Unit colour	Black	
Net Weight	3.2 Kg	
Mounting	Internal Mounting Holes	
Protection Rate	IP65	
Certification	RoHS, CE	
Warranty	3 Years	

Gemma LIGHTING LIMITED

Unit 3 , Marshlands Spur
Farlington
Portsmouth
Hampshire
PO6 1RX

Tel: +44 (0) 844 856 5201
Fax: +44 (0) 844 856 5209

Email: info@gemmalighting.com

