

Star 24 XL100 - LED 2D Bulkhead Light

Star - LED 2D Bulkhead Range

Star 16 XL100 AC
Star 16 XL100 DC

Star 24 XL100 AC
Star 24 XL100 DC

Alternative Products

Sun - LED Floodlight Range

Sun 12 XL100 AC
Sun 12 XL100 DC

Sun 24 XL100 AC
Sun 24 XL100 DC

Sun 48 XL100 AC
Sun 48 XL100 DC

Sun 72 XL100 AC
Sun 72 XL100 DC

Gemma LIGHTING LIMITED

Unit 3, Marshlands Spur
Farlington
Portsmouth
Hampshire
PO6 1RX

Tel: +44 (0) 844 856 5201
Fax: +44 (0) 844 856 5209

Email: info@gemmalighting.com



The **Star 24 LED 2D Bulkhead lights** are environmentally friendly replacements for traditional 2D bulkhead light fittings.

Typically using 50% less energy, these LED lights can significantly reduce energy consumption and cut carbon emissions. Ideal for reducing expenditure and helping with environmental issues.

These LED 2D Bulkhead lights are ready for connection to either AC mains power supply or our Mercury solar power management unit, which provides a flexible lighting solution where mains power is not available or desired.

The Star LED 2D Bulkhead Light is IP65 rated and comes in a vandal resistant fitting manufactured from strong pressure die-cast aluminium, with a flame-retardant polycarbonate cover and tamper-resistant cover screws as standard.

These luminaires are ideal for use in security area, subways, pedestrian areas, multi storey car parks and any environment prone to vandalism.

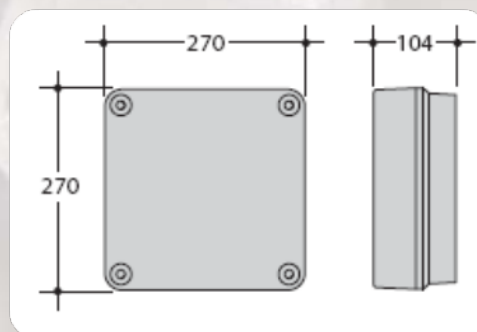
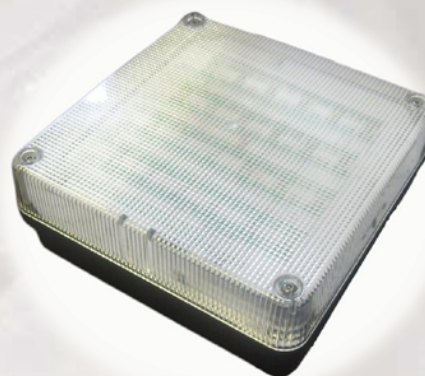

Specifications: Star 24 XL100 – LED 2D Bulkhead Light

	AC	DC
Product Code	ST2D-24-4S-2A	ST2D-24-4S-1D
Power Consumption	28 Watts	24 Watts
Input Voltage	230V AC 50Hz / 110V AC 60Hz	12 VDC
Light Source	1W High Power LED	
LED QTY	24	
Total LED Output	2400 lm	
Operating Lumens at 25°C	1800 lm	
LED Colour	Cool White	
Colour Temp (K)	5400 - 6300 degrees K (Standard)	
CRI	Ra>70	
LED Lifespan	>50,000 Hours	
Operating Temperature	-30 degrees C to + 70 degrees C	
Working Humidity	0 ~ 95%	
Turn on time	100ns	
Product Size (mm)	270mm x 270mm x 104mm	
Unit colour	Black	
Net Weight	3.2 Kg	
Mounting	Internal Mounting Holes	
Protection Rate	IP65	
Certification	RoHS, CE	
Warranty	3 Years	